

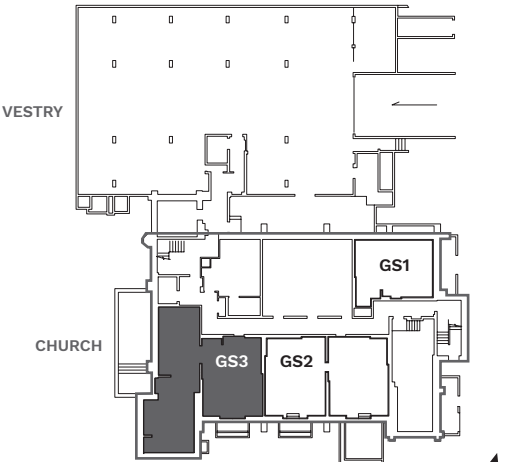

# Garden Suite 3

3 Bed + 1 Den 1440 Sq. Ft. + 339 Sq. Ft. Patio

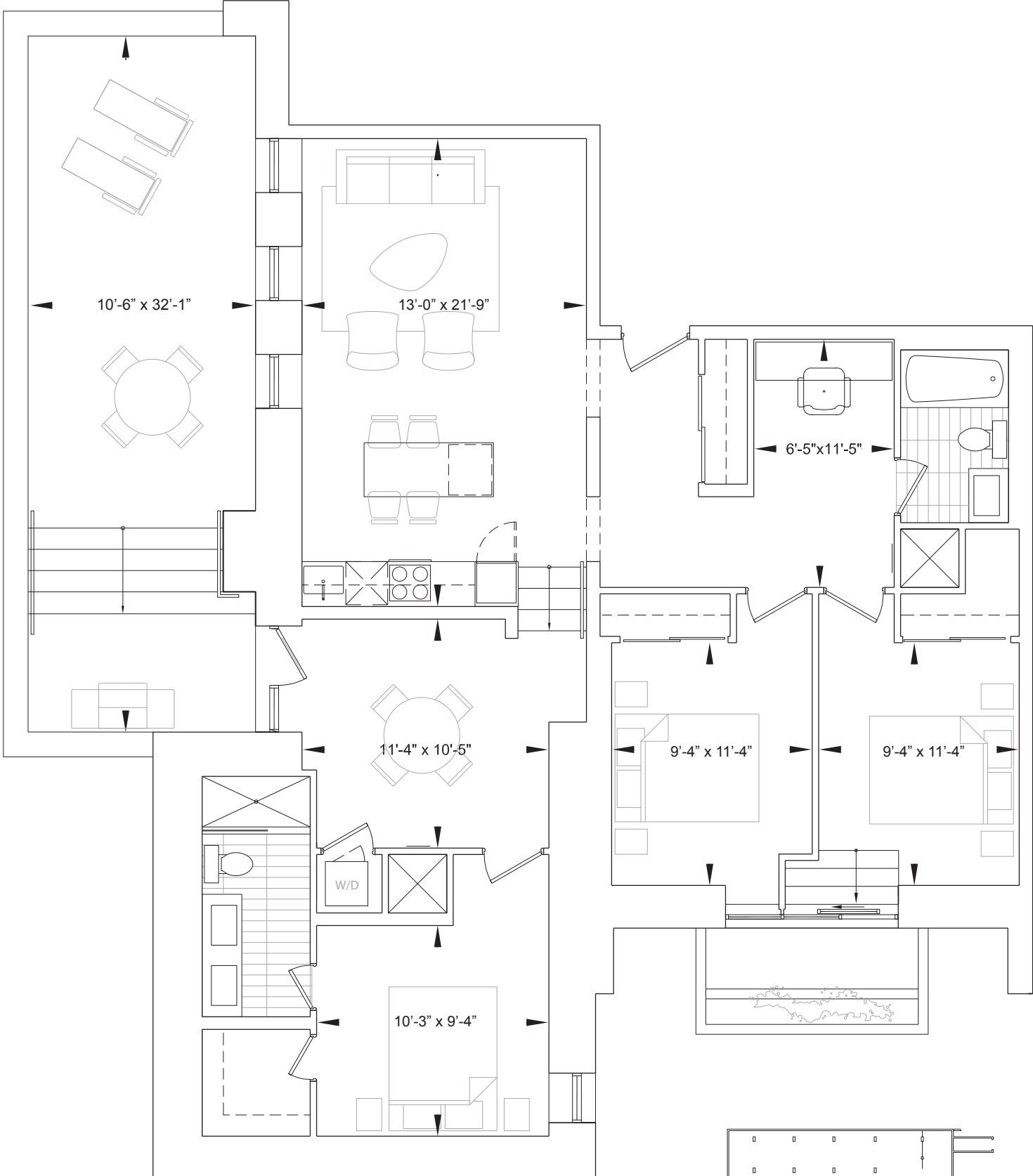

archlofts.com | 416-800-8796

All areas and stated room dimensions are approximate. Sizes and specifications are subject to change without notice. April 2017. E. & O.E.



# Church 105

2 Bed 1004 Sq. Ft. + 442 Sq. Ft. Patio

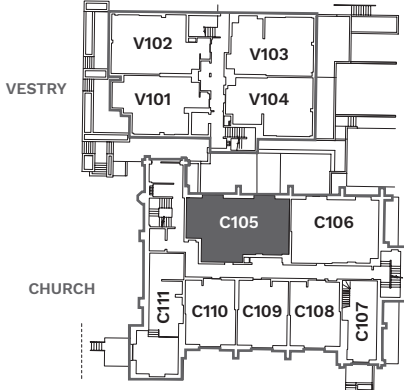
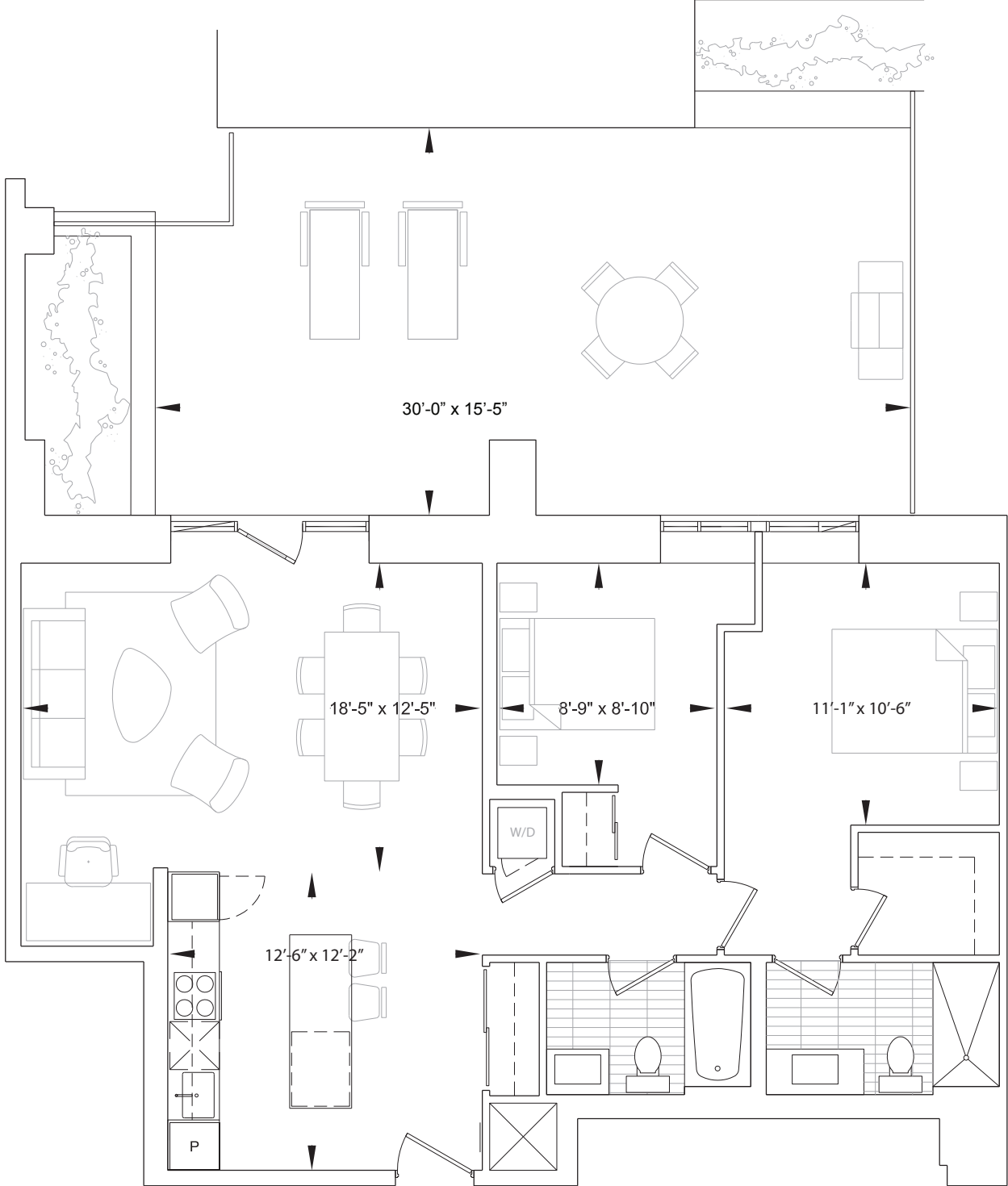

archlofts.com | 416-800-8796

All areas and stated room dimensions are approximate. Sizes and specifications are subject to change without notice. April 2017. E. & O.E.





# Church 107

1 Bed 1059 Sq. Ft. + 69 Sq. Ft. Terrace

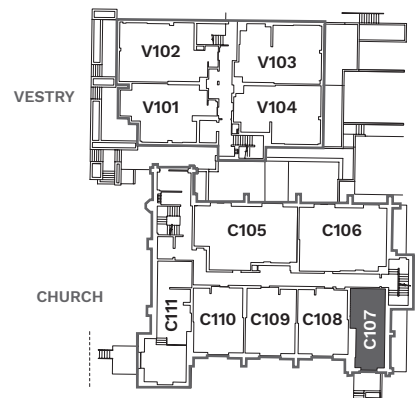
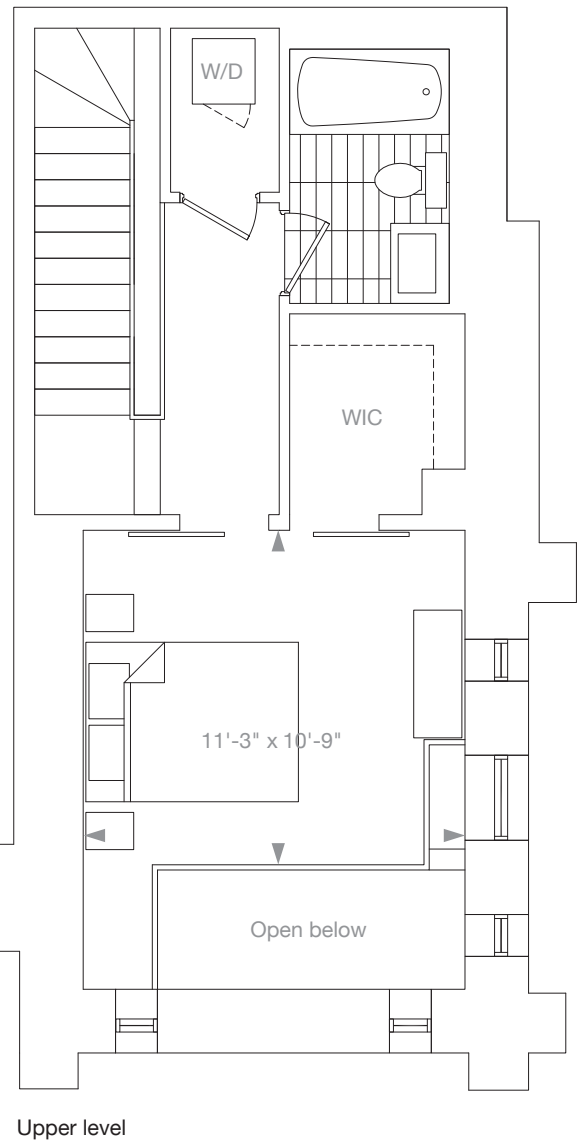
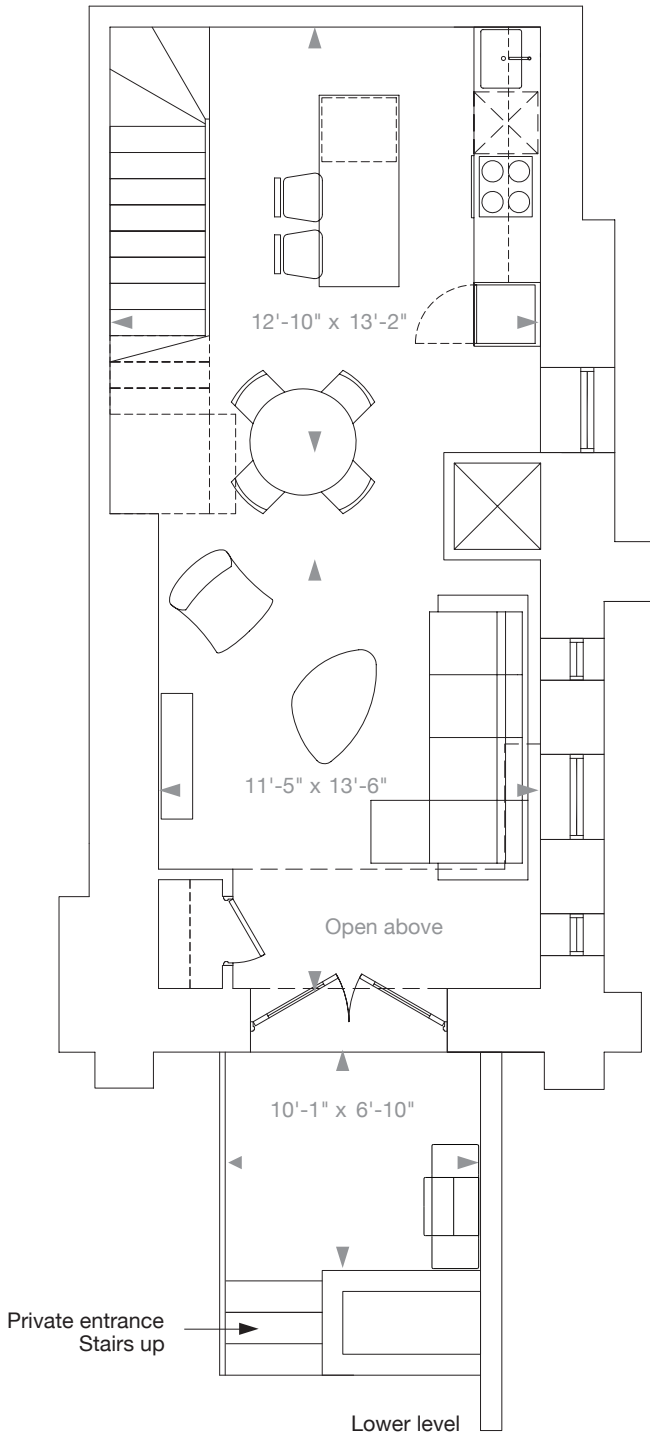

archlofts.com | 416-800-8796

All areas and stated room dimensions are approximate. Sizes and specifications are subject to change without notice. April 2017. E. & O.E.





# Church 111

1 Bed 878 Sq. Ft. + 108 Sq. Ft. Terrace

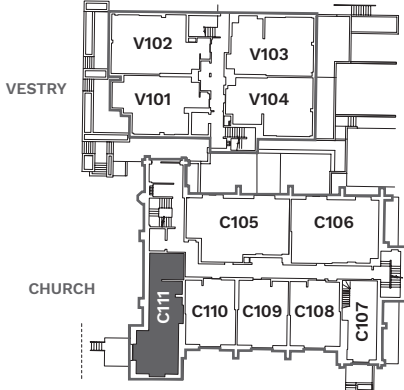
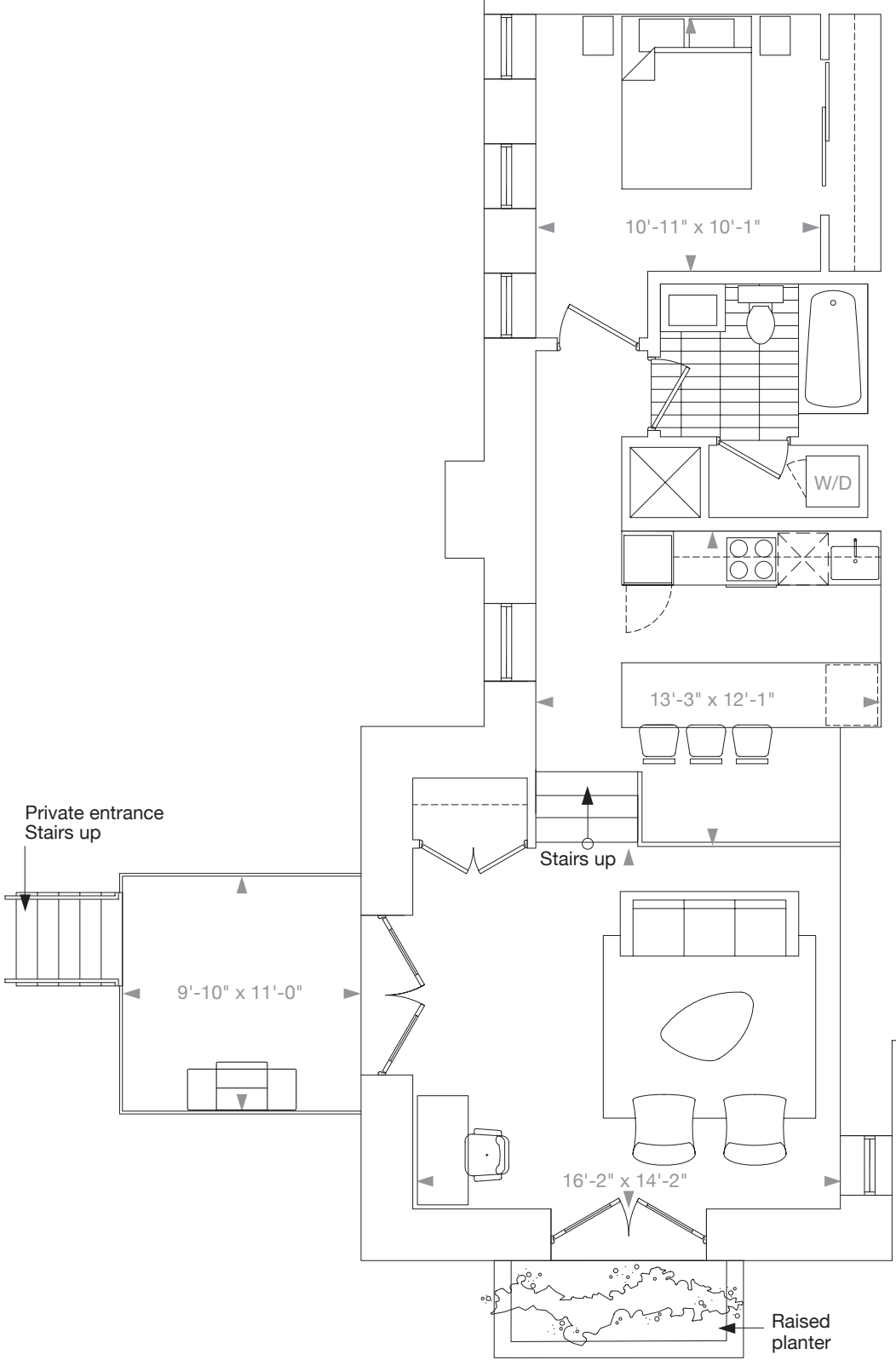

archlofts.com | 416-800-8796

All areas and stated room dimensions are approximate. Sizes and specifications are subject to change without notice. April 2017. E. & O.E.





# Church 305 PH

1 Bed 847 Sq. Ft. + 77 Sq. Ft. Terrace

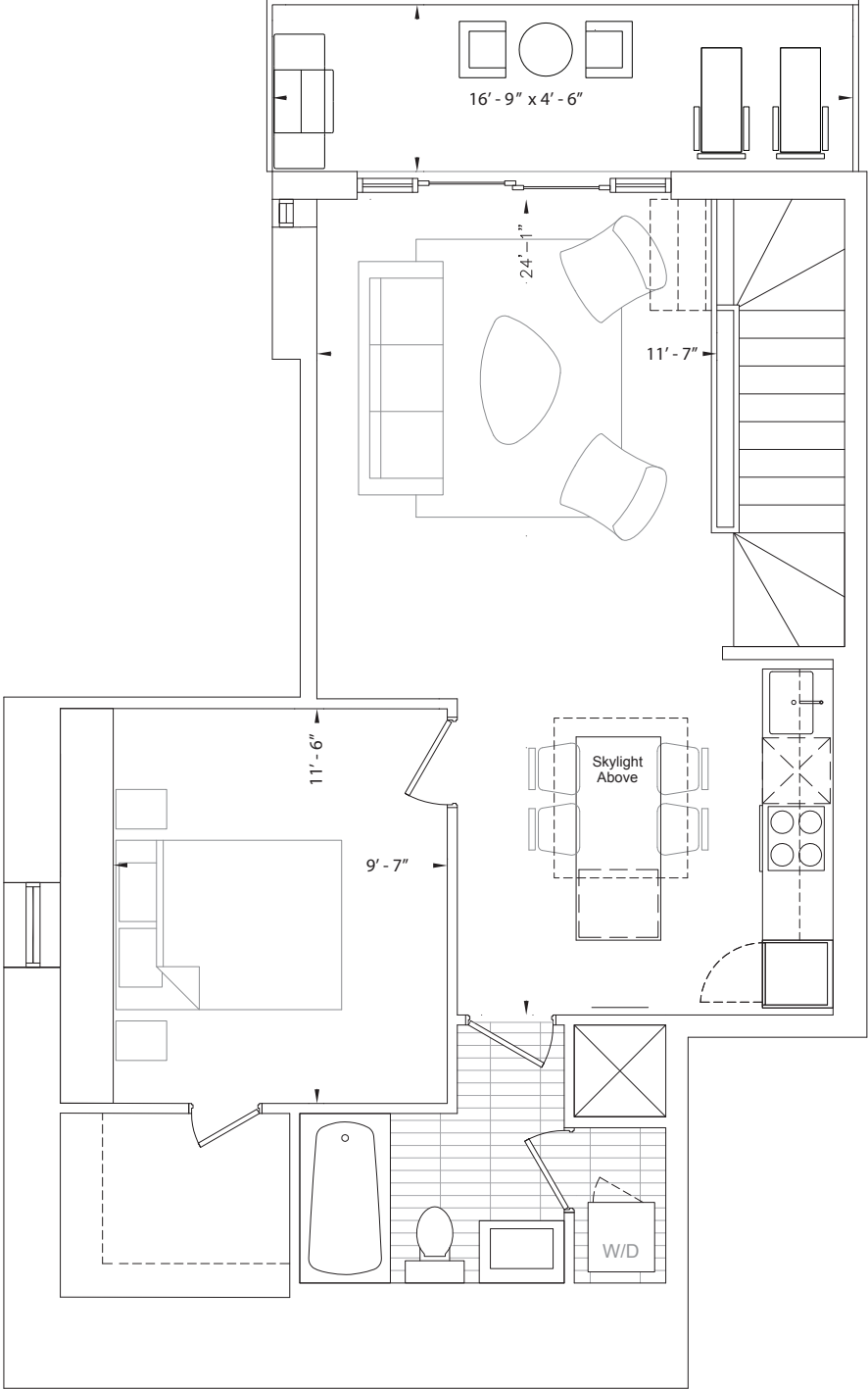
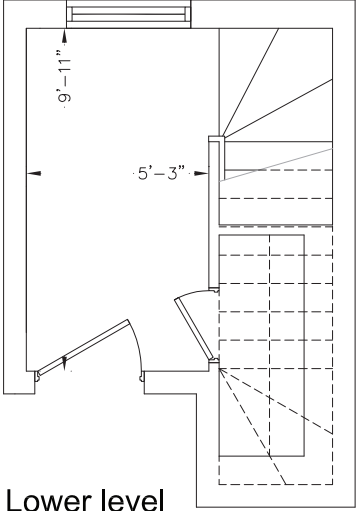

Upper level

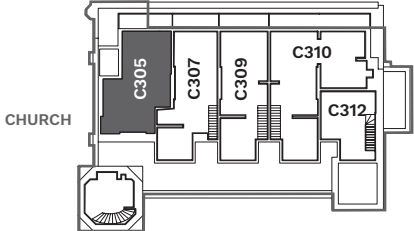
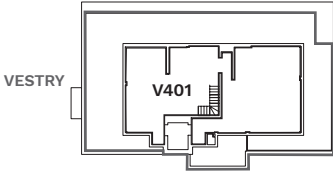



# Church 310 PH

2 Bed + Den 1074 Sq. Ft. + 143 Sq. Ft. Terrace

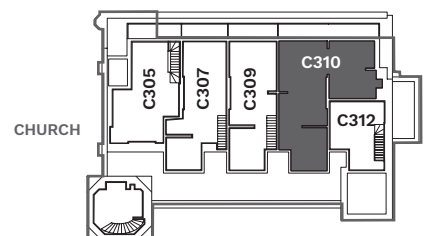
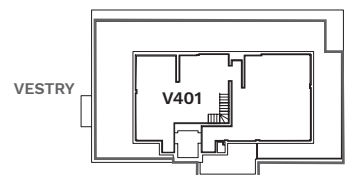
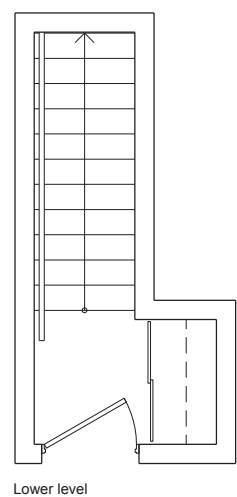
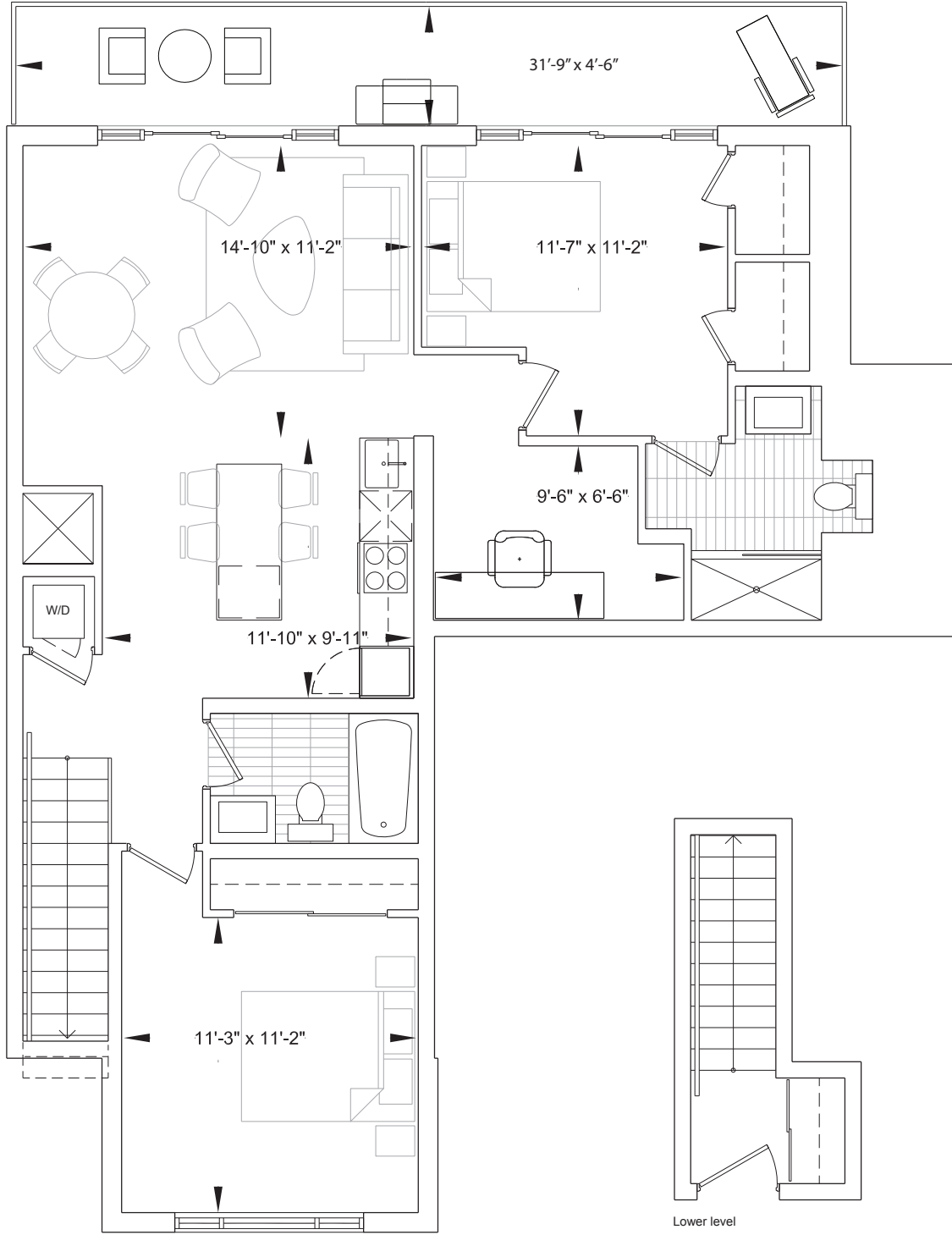

archlofts.com | 416-800-8796

All areas and stated room dimensions are approximate. Sizes and specifications are subject to change without notice.  
April 2017. E. & O.E.





# Vestry 101

1 Bed 753 Sq. Ft. + 186 Sq. Ft. Terrace

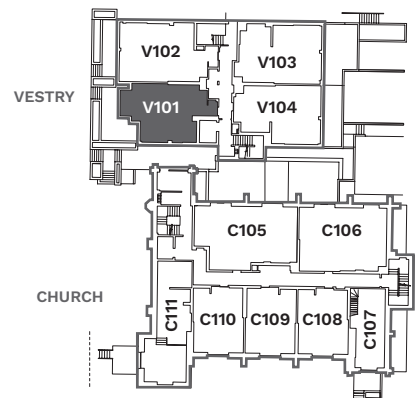
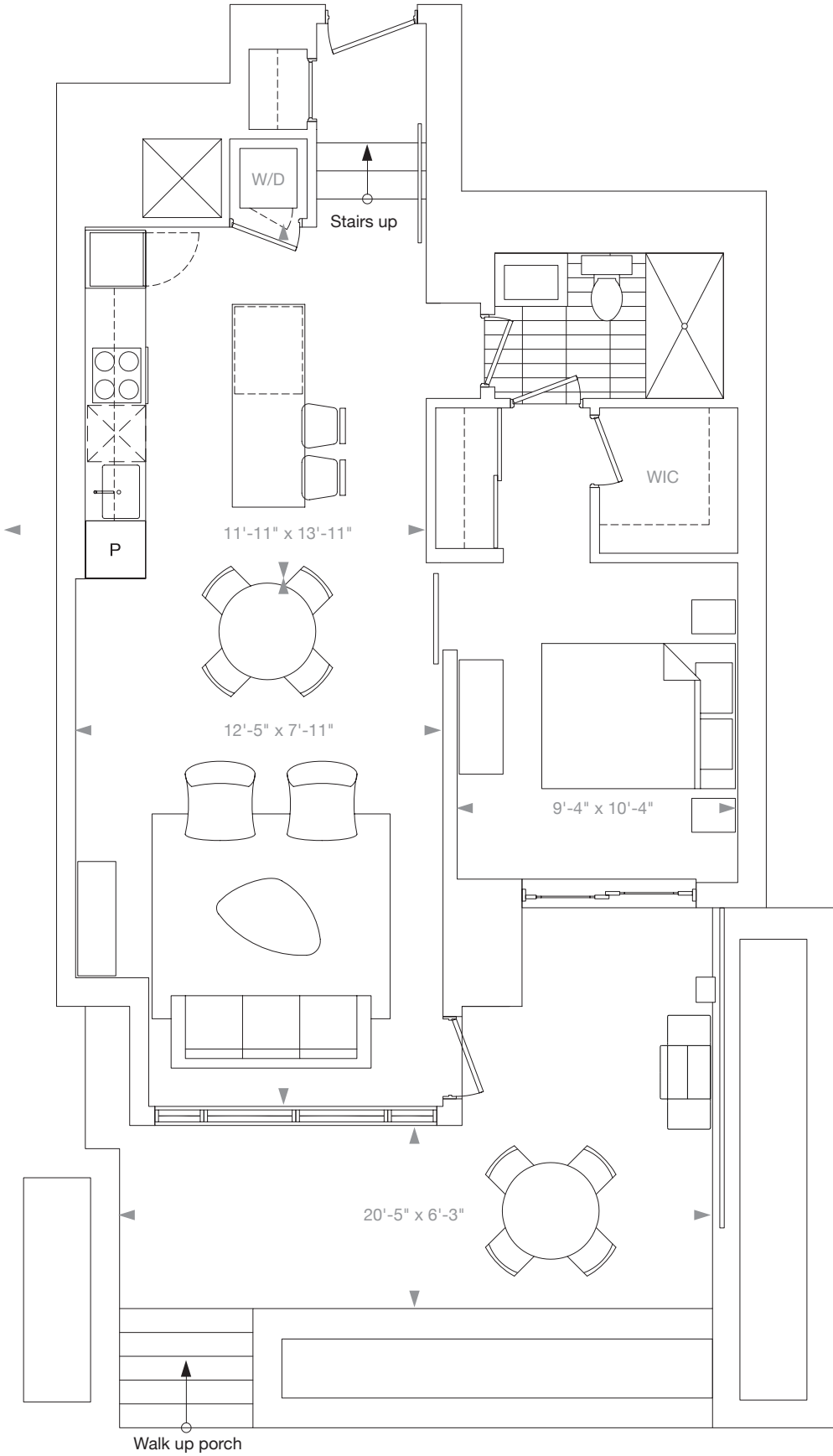

archlofts.com | 416-800-8796

All areas and stated room dimensions are approximate. Sizes and specifications are subject to change without notice. April 2017. E. & O.E.





# Vestry 103

2 Bed 817 Sq. Ft. + 268 Sq. Ft. Terrace

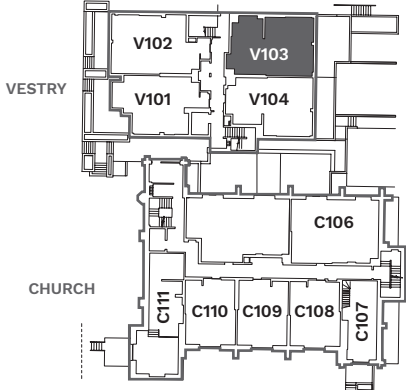
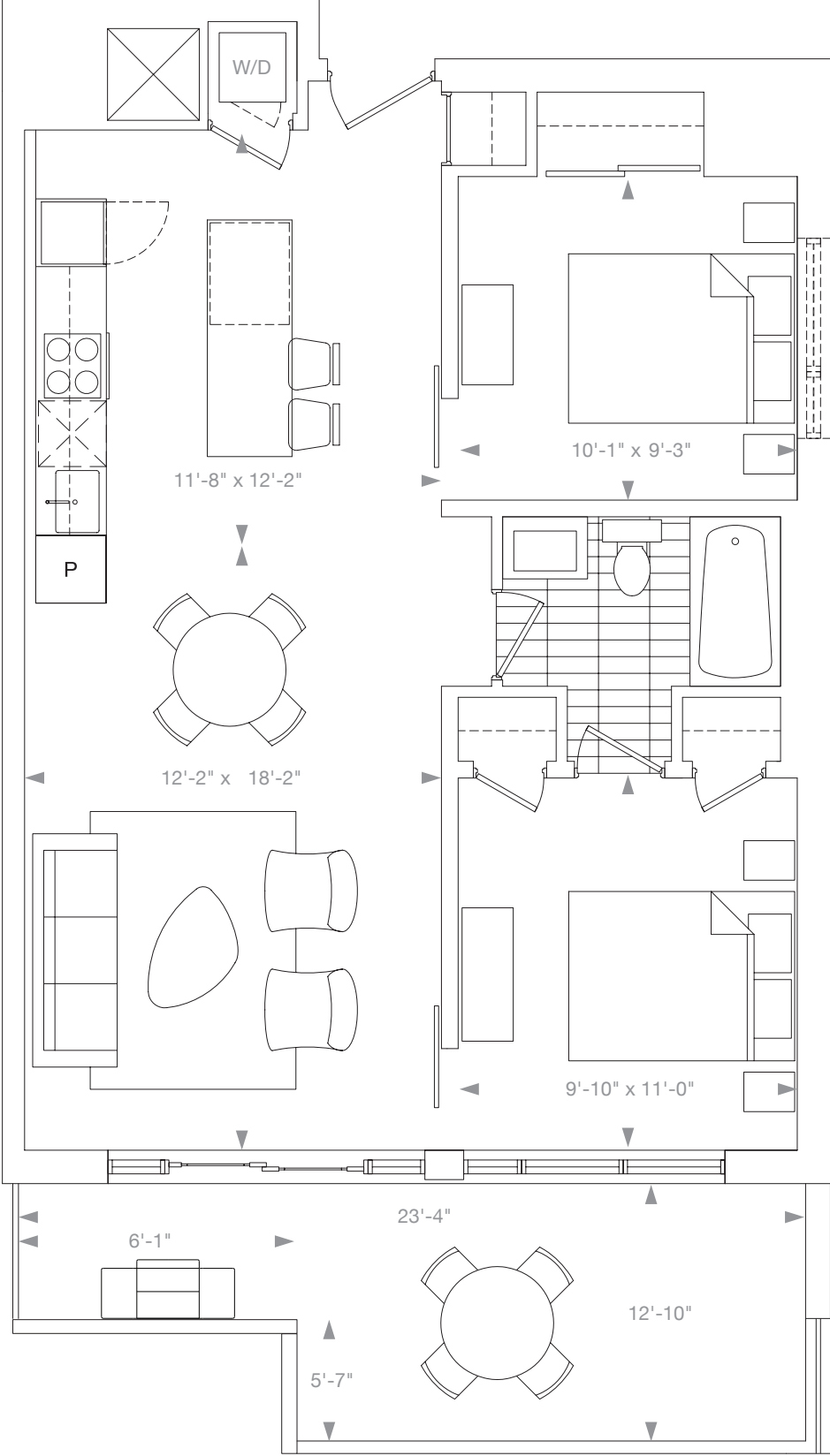

archlofts.com | 416-800-8796

All areas and stated room dimensions are approximate. Sizes and specifications are subject to change without notice. April 2017. E. & O.E.







# Vestry 201

1 Bed 784 Sq. Ft. + 53 Sq. Ft. Balcony

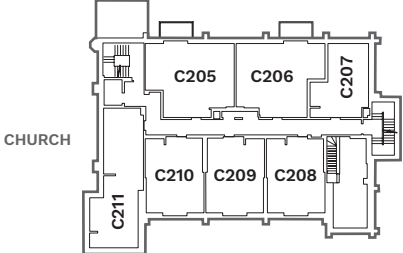
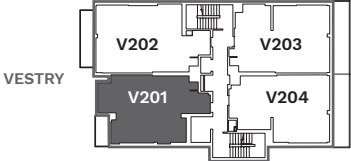
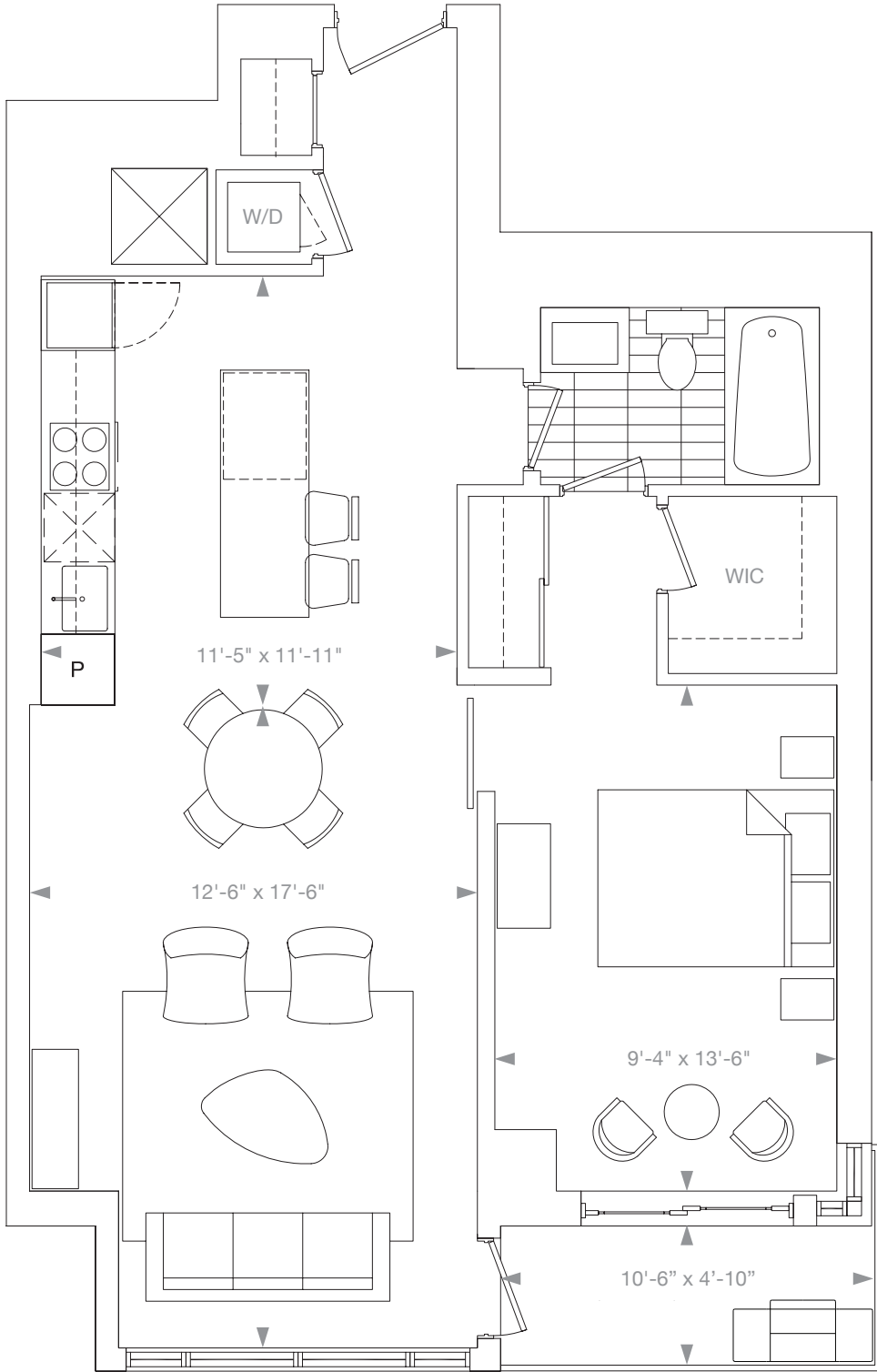

archlofts.com | 416-800-8796

All areas and stated room dimensions are approximate. Sizes and specifications are subject to change without notice. April 2017. E. & O.E.





# Vestry 202

2 Bed 852 Sq. Ft. + 97 Sq. Ft. Balcony

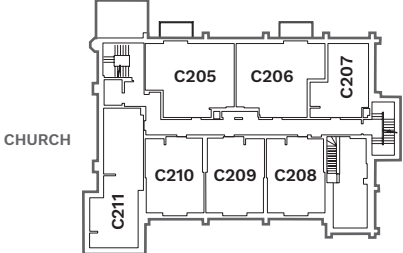
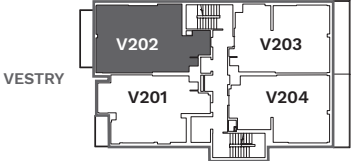
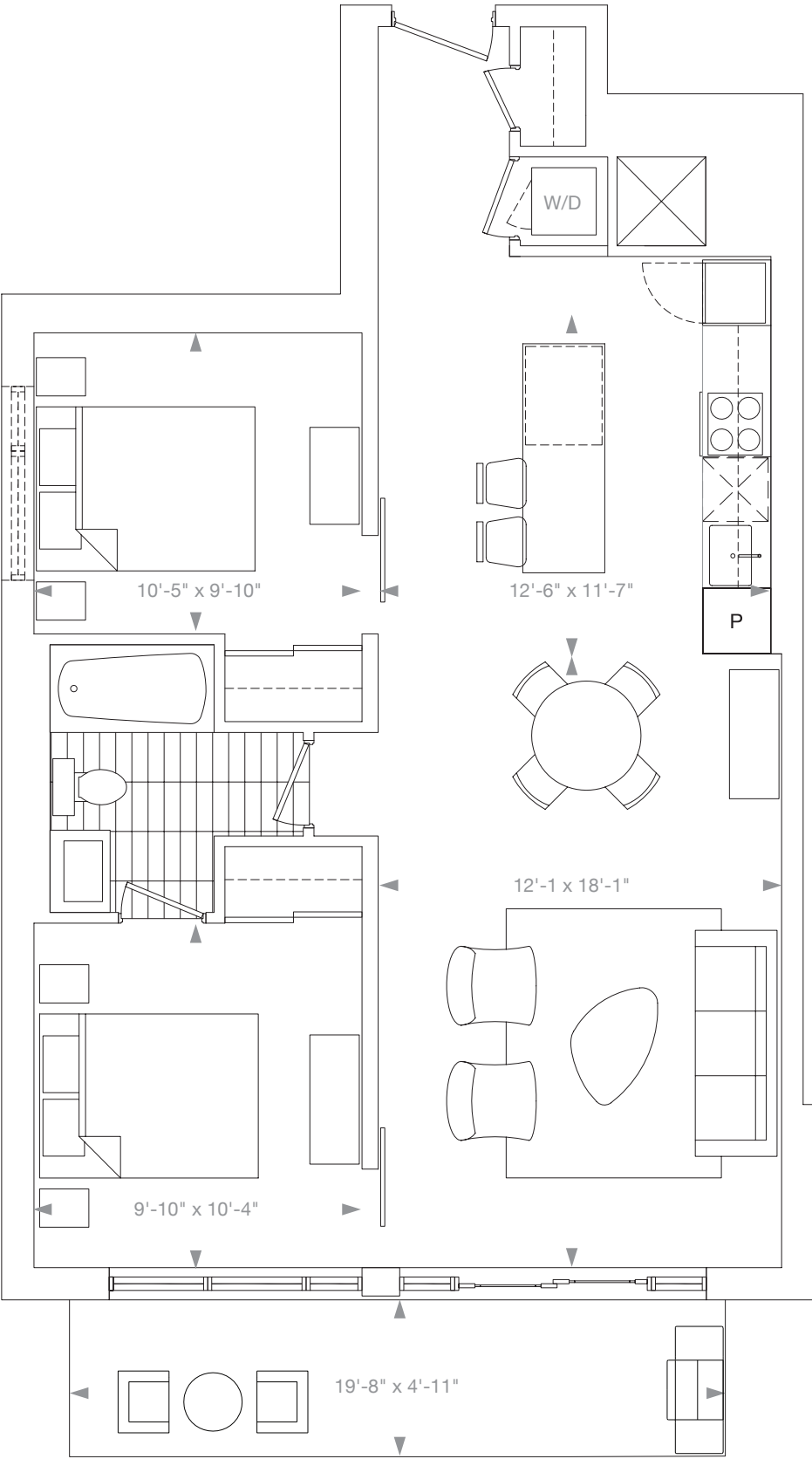

archlofts.com | 416-800-8796

All areas and stated room dimensions are approximate. Sizes and specifications are subject to change without notice. April 2017. E. & O.E.





# Vestry 302

1 Bed 726 Sq. Ft. + 79 Sq. Ft. Balcony

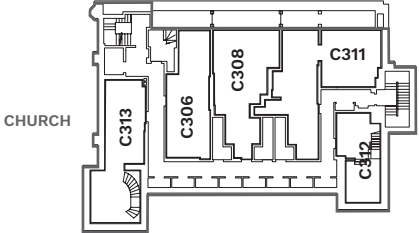
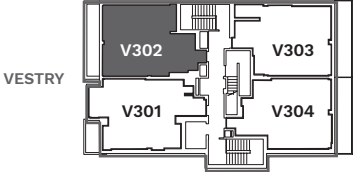
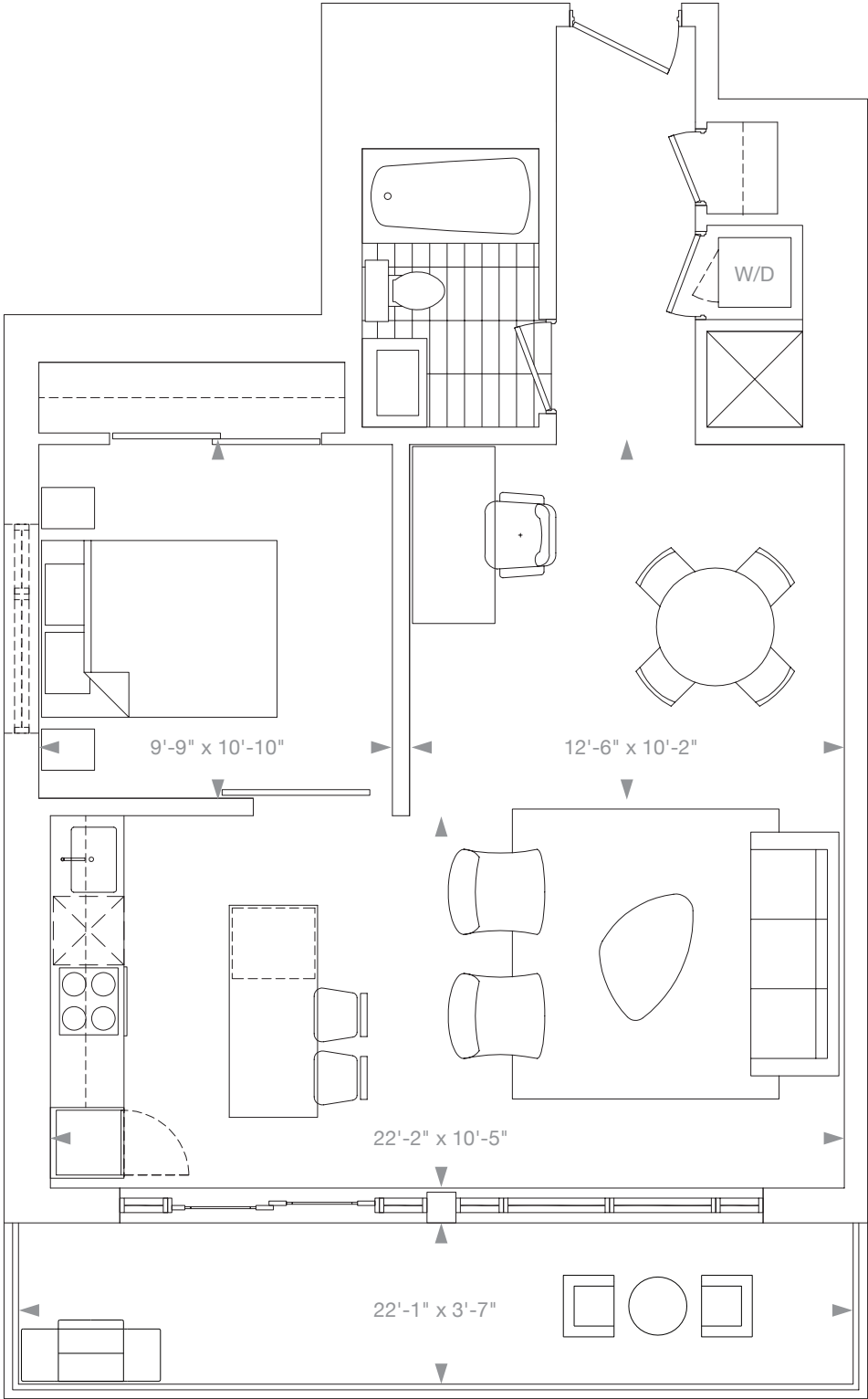

archlofts.com | 416-800-8796

All areas and stated room dimensions are approximate. Sizes and specifications are subject to change without notice. April 2017. E. & O.E.





# Vestry 401 PH

3 Bed 1834 Sq. Ft. + 1580 Sq. Ft. Terrace

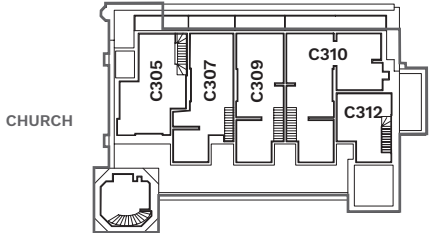
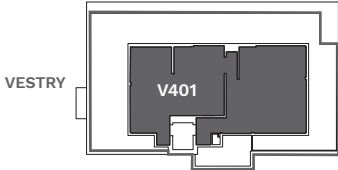
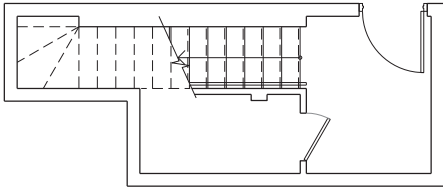
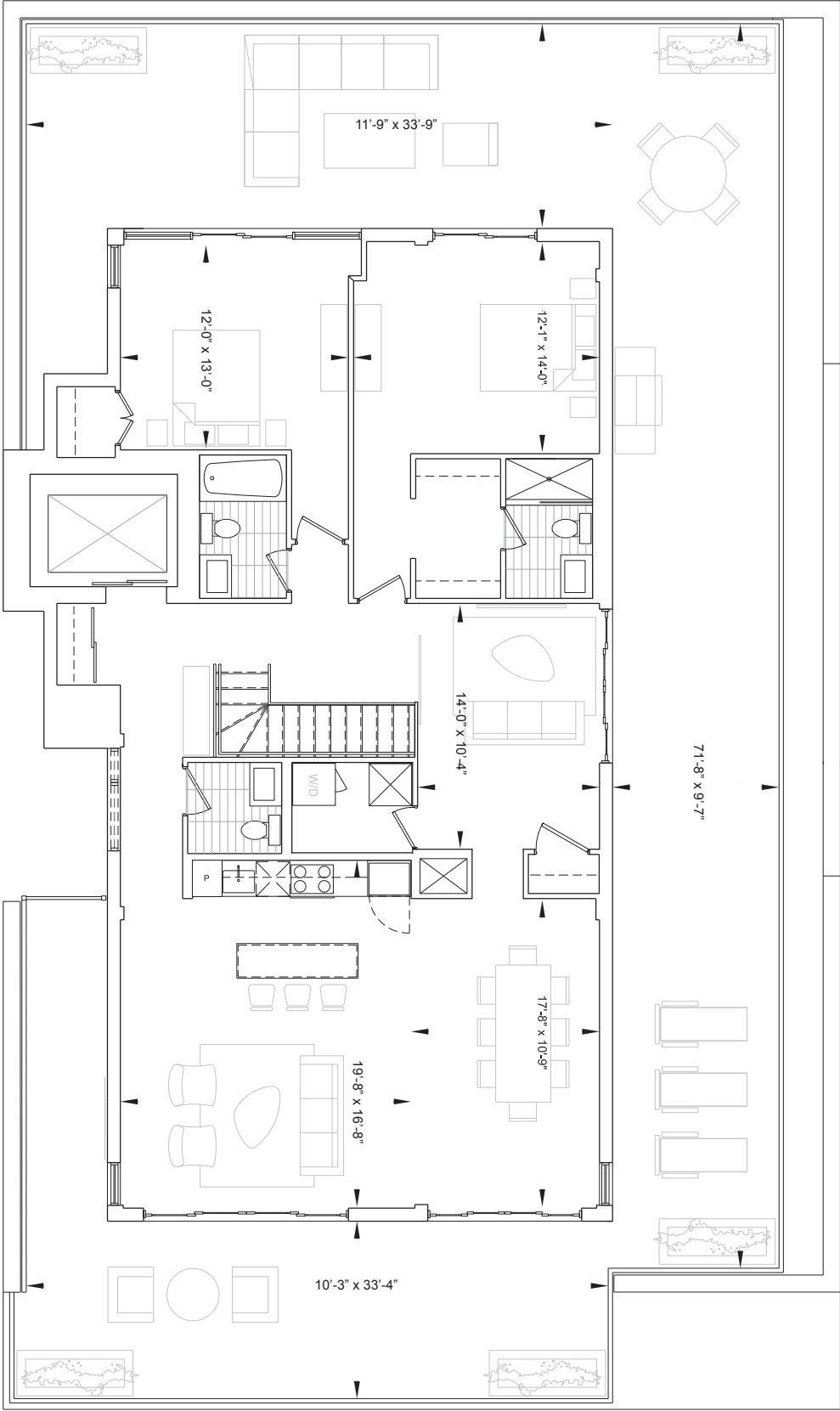

archlofts.com | 416-800-8796

All areas and stated room dimensions are approximate. Sizes and specifications are subject to change without notice.  
April 2017. E. & O.E.

